

GENERAL DESCRIPTION

OB2513x is a high performance offline PSR power switch for low power AC/DC charger and adapter applications. It operates in primary-side sensing and regulation. Consequently, opto-coupler and TL431 could be eliminated. Proprietary Constant Voltage (CV) and Constant Current (CC) control is integrated as shown in the figure below.

In CC control, the current and output power setting can be adjusted externally by the sense resistor R_s at CS pin. In CV control, multi-mode operations are utilized to achieve high performance and high efficiency. In addition, good load regulation is achieved by the built-in cable drop compensation. Device operates in PFM in CC mode as well at large load condition and it operates in PWM with frequency reduction at light/medium load. The chip consumes very low operation current, it can achieve less than 75mW standby power.

OB2513x offers comprehensive protection coverage with auto-recovery features including Cycle-by-Cycle current limiting, VDD over voltage protection, short circuit protection, built-in leading edge blanking, VDD under voltage lockout (UVLO), OTP etc.

OB2513x is offered in SOP7 package.

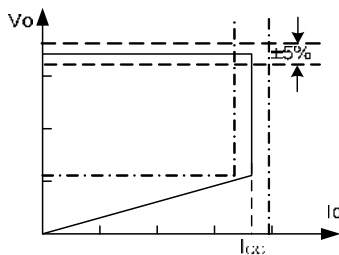

Figure.1. Typical CC/CV Curve

FEATURES

- Primary-side sensing and regulation without TL431 and opto-coupler
- High precision constant voltage and current regulation at universal AC input
- Multi-mode PWM/PFM operation for efficiency improving
- Good dynamic response
- Programmable CV and CC regulation
- Built-in line voltage and primary winding inductance compensation
- Programmable cable drop compensation
- No need for control loop compensation
- Audio noise free operation
- Internal BJT switch
- Built-in leading edge blanking (LEB)
- Comprehensive protection coverage with auto-recovery
 - VDD over voltage protection
 - VDD under voltage lockout with hysteresis (UVLO)
 - Cycle-by-cycle current limiting
 - Feedback loop open protection
 - Output short circuit protection
 - Over temperature protection (OTP)

APPLICATIONS

Low Power AC/DC offline SMPS for

- Cell Phone Charger
- Digital Cameras Charger
- Small Power Adapter
- Auxiliary Power for PC, TV etc.
- Linear Regulator/RCC Replacement

TYPICAL APPLICATION

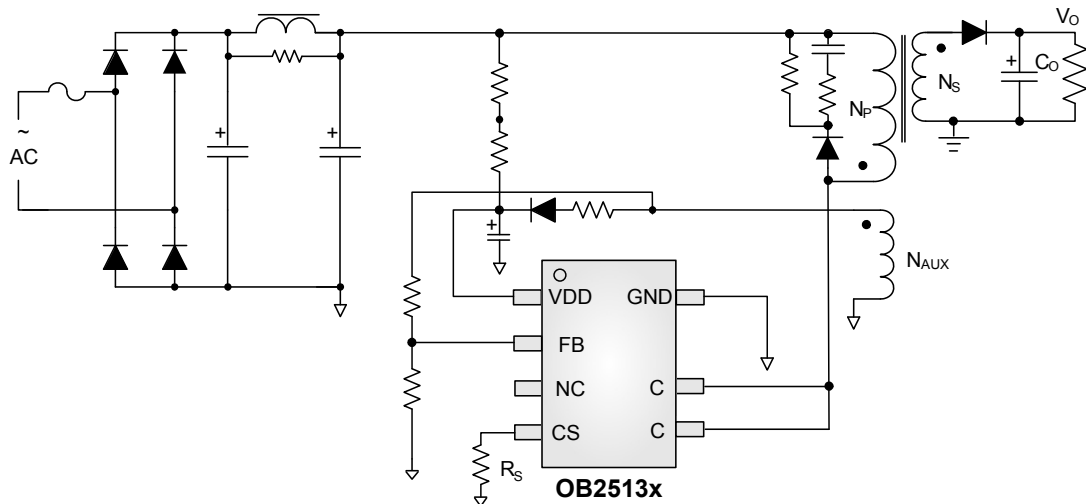

GENERAL INFORMATION

Pin Configuration

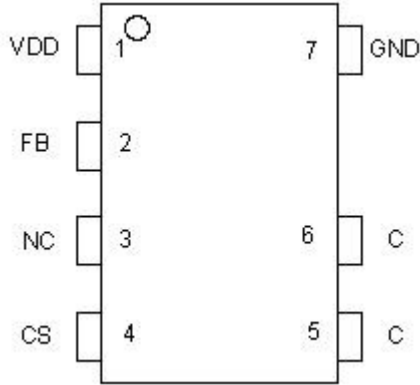

Absolute Maximum Ratings

Parameter	Value
OB2513x CB Voltage	800V
VDD Voltage	-0.3 to 20V
FB Input Voltage	-0.3 to 7V
CS Input Voltage	-0.3 to 7V
Min/Max Operating Junction Temperature T_J	-40 to 150 °C
Operating Temperature T_A Ambient	-20 to 85 °C
Min/Max Storage Temperature T_{stg}	-55 to 150 °C
Lead Temperature (Soldering, 10secs)	260 °C

Note: Stresses beyond those listed under “absolute maximum ratings” may cause permanent damage to the device. These are stress ratings only, functional operation of the device at these or any other conditions beyond those indicated under “recommended operating conditions” is not implied. Exposure to absolute maximum-rated conditions for extended periods may affect device reliability.

Ordering Information

Part Number	Description
OB2513xJP	SOP7, Pb-free, Tube
OB2513xJPA	SOP7, Pb-free, T&R

Package Dissipation Rating

Package	R θ JA (°C/W)
SOP7	95

Recommended Operating Condition

Symbol	Parameter	Range
VDD	VDD Supply Voltage	5 to 16V

Recommended Output power Table

Product	Adapter ^{Note1}
	90V~264V
OB25132	3.5W
OB25133	5.0W
OB25134	7.5W

Notes: 1. Maximum practical continuous power in an adapter design with sufficient drain pattern as a heat sink, at 40°C ambient

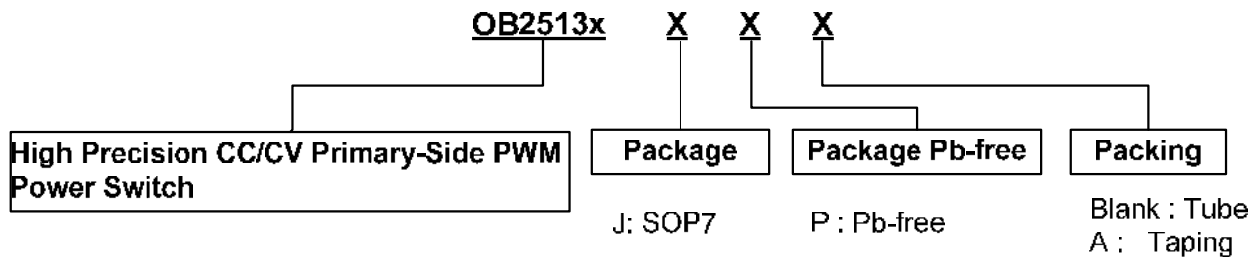

Marking Information

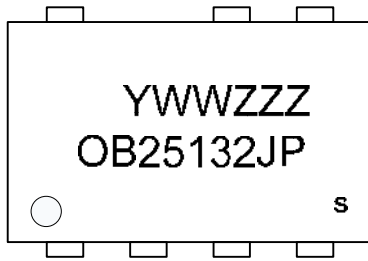

Y:Year Code
WW:Week Code(01-52)
ZZZ:Lot Code
J:SOP7 Package
P:Pb-free Package
S:Internal Code(Optional)

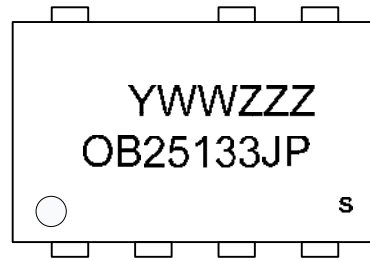

Y:Year Code
WW:Week Code(01-52)
ZZZ:Lot Code
J:SOP7 Package
P:Pb-free Package
S:Internal Code(Optional)



Y:Year Code
WW:Week Code(01-52)
ZZZ:Lot Code
J:SOP7 Package
P:Pb-free Package
S:Internal Code(Optional)

TERMINAL ASSIGNMENTS

Pin Num	Pin Name	I/O	Description
1	VDD	P	Power Supply
2	FB	I	The voltage feedback from auxiliary winding. Connected to resistor divider from auxiliary winding reflecting output voltage.
3	NC		
4	CS	I	Current sense input
5、6	C	P	HV BJT collector pin.
7	GND	P	Ground

BLOCK DIAGRAM

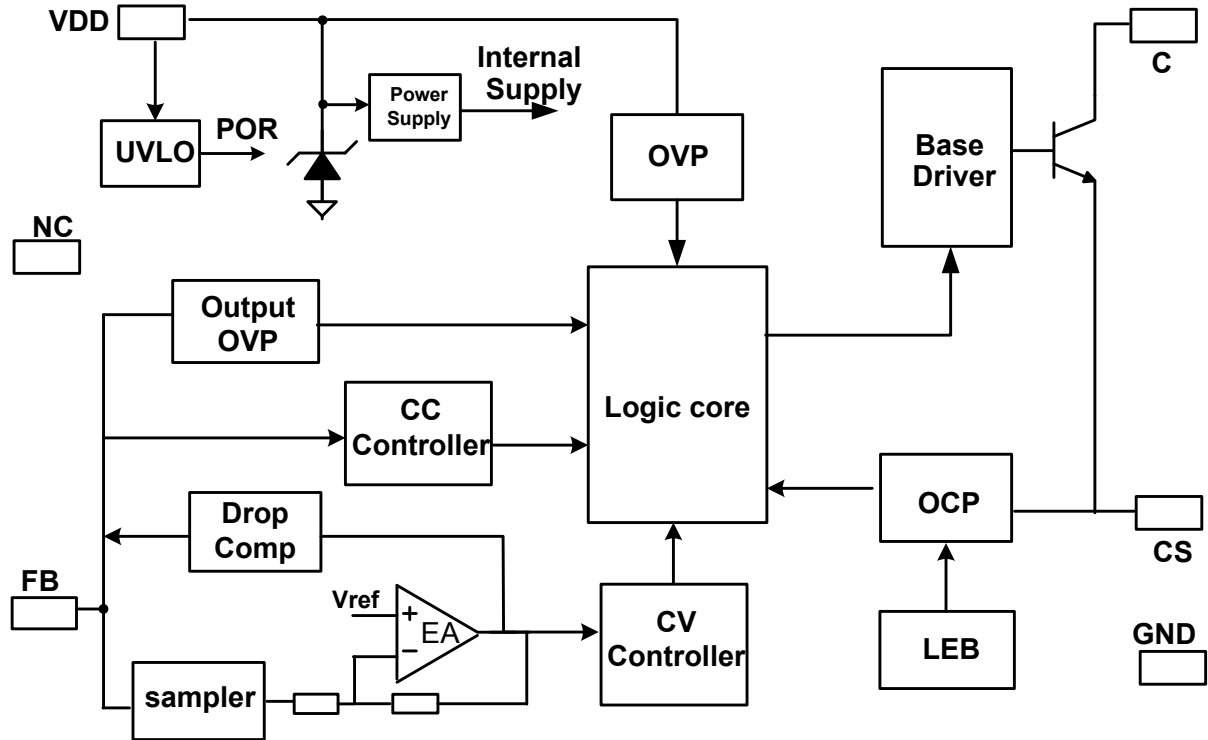

ELECTRICAL CHARACTERISTICS

(TA = 25°C, VDD=15V, if not otherwise noted)

Symbol	Parameter	Test Conditions	Min	Typ.	Max	Unit
Supply Voltage (VDD) Section						
I _{start-up}	Start up current	VDD=UVLO_OFF-1V		1	3	uA
I _{op}	Operation current without switching			0.77	1.0	mA
UVLO(OFF)	VDD under voltage lockout exit		12	13	14	V
UVLO(ON)	VDD under voltage lockout enter		3.5	3.7	3.9	V
VDD_OVP	VDD over voltage protection		17	18	19	V
VDD_max	Max. Operating Voltage				16	V
Current Sense Input Section						
TLEB	LEB time			0.33		us
V _{th_ocp_min}	Minimum over current threshold		485	500	515	mV
V _{th_ocp_max}	Maximum over current threshold			555		mV
T _{on_max}	Maximum Ton			40		us
T _{d_oc}	OCP propagation delay			100		ns
FB Input Section						
V _{ref_fb}	Reference voltage for feedback threshold		2.475	2.500	2.525	V
T _{pause_min}	Minimum Toff			2.0		us
F _{min}	Minimum frequency		450	500	550	Hz
F _{max}	Maximum frequency		90			KHz
I _{comp_cable}	Maximum cable compensation current			53		uA
Output Over Voltage Protection						
V _{ovp}	Output Over voltage threshold		2.85	3.00	3.15	V
On chip Over temperature Section						
T _{otp}	Over temperature protection trigger point			165		°C
T _{otp_rec}	Over temperature protection recovery point			130		°C

Power BJT Section									
Parameter Product	V _{ceo} (V) ^{Note1}			V _{cbo} (V) ^{Note2}			I _c (A)		
	Collector-emitter breakdown voltage			Collector-base breakdown voltage			Collect Peak Current		
	Min.	Typ.	Max.	Min.	Typ.	Max.	Min.	Typ.	Max.
OB25132		450		800				0.35	
OB25133		450		800				0.50	
OB25134		450		800				0.8	

Note1: Test condition: I_c=10mA, I_b=0

Note2: Test condition: $I_c=10\text{mA}$

CHARACTERIZATION PLOTS

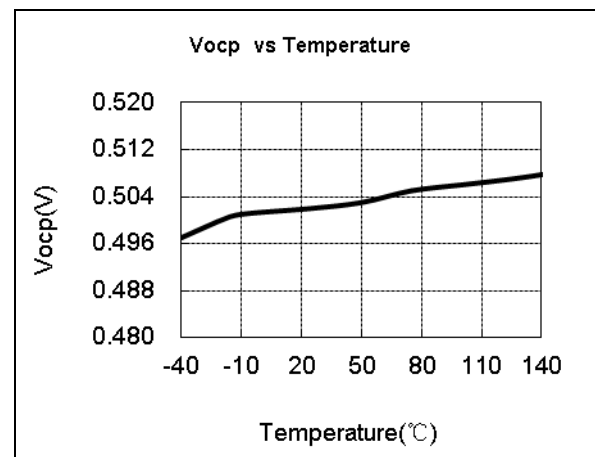
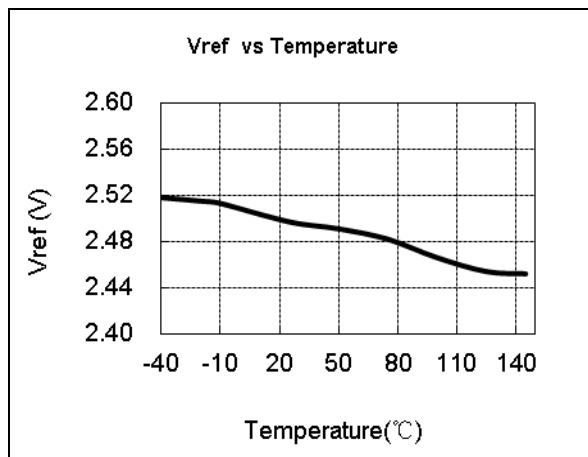
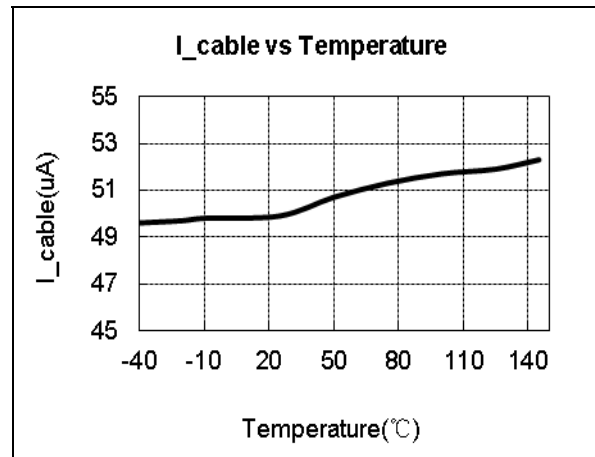
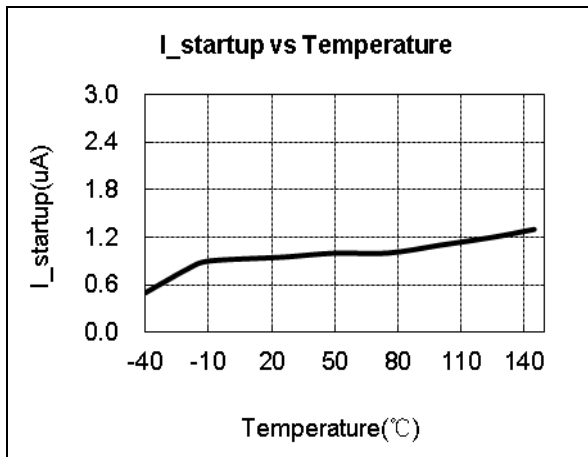
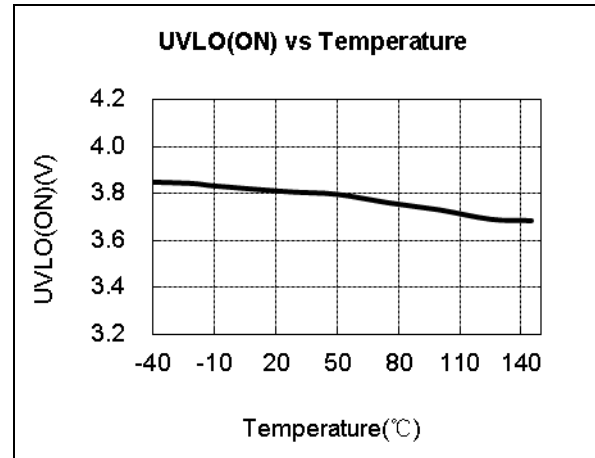
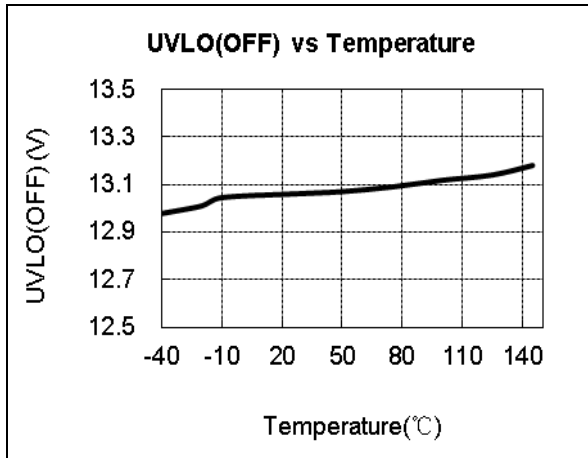

OPERATION DESCRIPTION

OB2513x is a cost effective PSR power switch optimized for off-line low power AC/DC applications including battery chargers. It operates in primary side sensing and regulation, thus opto-coupler and TL431 are not required. Proprietary built-in CV and CC control can achieve high precision CC/CV control meeting most charger application requirements.

Startup Current and Startup Control

Startup current of OB2513x is designed to be very low so that VDD can be charged up quickly. A large value startup resistor can therefore be used to minimize the power loss in application.

Operating Current

The operating current of OB2513x is as low as 550uA (typical). Good efficiency and low standby power is achieved with the low operating current.

CC/CV Operation

OB2513x is designed to produce good CC/CV control characteristic as shown in the Figure. 1. In charger applications, a discharged battery charging starts in the CC portion of the curve until it is nearly full charged and smoothly switches to operate in CV portion of the curve. The CC portion provides output current limiting. In CV operation, the output voltage is regulated through the primary side control. In CC operation mode, OB2513x will regulate the output current constant regardless of the output voltage drop.

Principle of Operation

To support OB2513x proprietary CC/CV control, system needs to be designed in DCM mode for flyback system (Refer to Typical Application Diagram on page1).

In the DCM flyback converter, the output voltage can be sensed via the auxiliary winding. During BJT turn-on time, the load current is supplied from the output filter capacitor, Co. The current in the primary winding ramps up. When BJT turns off, the energy stored in the primary winding is transferred to the secondary side such that the current in the secondary winding is

$$I_S = \frac{N_P}{N_S} \cdot I_P \quad (1)$$

The auxiliary voltage reflects the output voltage as shown in Figure.2 and it is given by

$$V_{AUX} = \frac{N_{AUX}}{N_S} \cdot (V_O + \Delta V) \quad (2)$$

Where ΔV indicates the drop voltage of the output Diode.

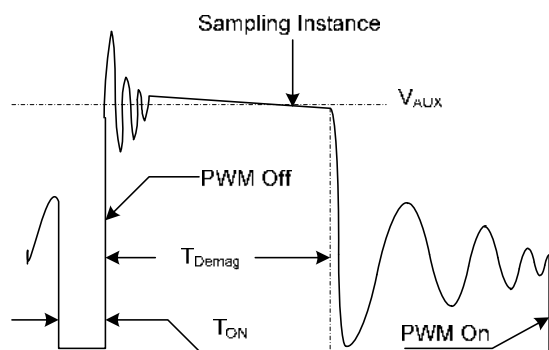

Figure 2 Auxiliary voltage waveform

Via a resistor divider connected between the auxiliary winding and FB, the auxiliary voltage is sampled and hold during the demagnetization cycle. The sampling instance is variable according to the demagnetization width. The output voltage can be monitored when the secondary current is small. Thus ΔV can be ignored. The sampled voltage is compared with reference voltage V_{ref_EA} and the difference is amplified by the error amplifier. The error amplifier output reflects the load condition and controls the switching off time to regulate the output voltage, thus constant output voltage can be achieved.

When the sampled voltage is below V_{ref_EA} and the error amplifier output reaches its maximum, the switching frequency is controlled by the sampled voltage to regulate the output current, thus the constant output current can be achieved.

Adjustable CC Point and Output Power

In OB2513x, the CC point and maximum output power can be externally adjusted by external current sense resistor R_s at CS pin as illustrated in typical application diagram. The larger R_s , the smaller CC point is, and the smaller output power becomes, and vice versa as shown in Figure.3.

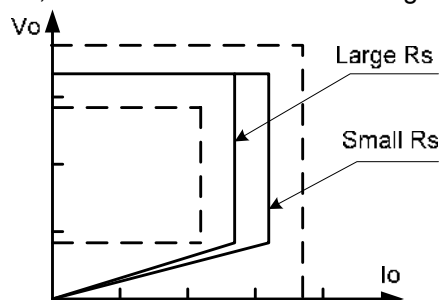

Figure 3. Adjustable output power by changing R_s

On Time OCP Compensation

The variation of max output current in CC mode can be rather large if no compensation is provided. The OCP threshold value is self adjusted higher at higher AC voltage. This OCP threshold slope adjustment helps to compensate the increased output current limit at higher AC voltage. In

OB2513x, a proprietary OCP compensation block is integrated and no external components are needed. The OCP threshold in OB2513x is a function of the switching ON time. For the ON time less than 4.0us (typical), the OCP threshold changes linearly from 500mV (typical) to 555mV (typical). For the ON time larger than 4.0us (typical), the OCP threshold is clamped to 555mV (typical), as shown in Figure 4.

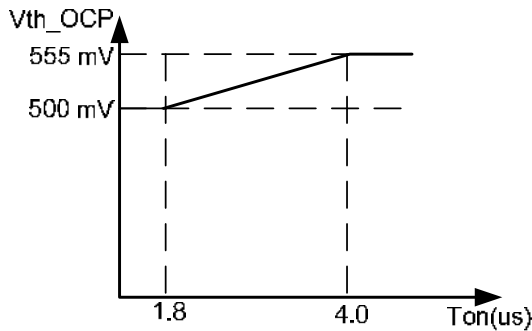

Figure.4. On time OCP compensation

Operation Switching Frequency

The switching frequency of OB2513x is adaptively controlled according to the load conditions and the operation modes.

For flyback operating in DCM, The maximum output power is given by

$$P_{O_{MAX}} = \frac{1}{2} L_p F_{SW} I_p^2 \quad (3)$$

Where L_p indicate the inductance of primary winding and I_p is the peak current of primary winding.

Refer to the equation 3, the change of the primary winding inductance results in the change of the maximum output power and the constant output current in CC mode. To compensate the change from variations of primary winding inductance, the switching frequency is locked by an internal loop such that the switching frequency is

$$F_{SW} = \frac{1}{2T_{Demag}} \quad (4)$$

Since T_{Demag} is inversely proportional to the switching frequency, as a result, the product L_p and f_{sw} is constant, thus the maximum output power and constant current in CC mode will not change as primary winding inductance changes. Up to $\pm 7\%$ variation of the primary winding inductance can be compensated.

Programmable Cable Drop Compensation

In OB2513x, cable drop compensation is implemented to achieve good load regulation. An offset voltage is generated at FB pin by an internal current flowing into the resistor divider. The current is proportional to the switching off time, as a result,

it is inversely proportional to the output load current, thus the drop due to the cable loss can be compensated. As the load current decreases from full-load to no-load, the offset voltage at FB will increase. It can also be programmed by adjusting the resistance of the divider to compensate the drop for various cable lines used.

The percentage of maximum compensation is

$$\frac{\Delta V}{V_{out}} = \frac{I_{comp_cable} \times R_1 // R_2 \times 10^{-6}}{2.5} \times 100\%$$

ΔV is load compensation voltage and V_{out} is output voltage;

For example: $R_1 // R_2 = 5.1\text{Kohm}$, the percentage of maximum compensation is

$$\frac{\Delta V}{V_{out}} = \frac{53 \times 5100 \times 10^{-6}}{2.5} \times 100\% = 10.8\%$$

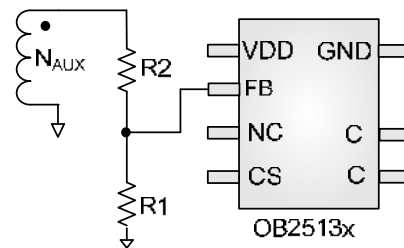

Current Sensing and Leading Edge Blanking

Cycle-by-Cycle current limiting is offered in OB2513x. The switch current is detected by a sense resistor into the CS pin. An internal leading edge blanking circuit chops off the sensed voltage spike at initial power BJT on state so that the external RC filtering on sense input is no longer needed.

Protection Control

Good power supply system reliability is achieved with its rich protection features including Cycle-by-Cycle current limiting (OCP), Output over voltage protection, VDD over voltage protection, short circuit protection, Under Voltage Lockout on VDD (UVLO) and over temperature protection (OTP).

VDD is supplied by transformer auxiliary winding output. The output of OB2513x is shut down when VDD drops below UVLO (ON) and the power converter enters power on start-up sequence thereafter.

To prevent the circuit being damaged under abnormal conditions, OB2513x provides over thermal protection function. When the die temperature rises above over temperature threshold T_{otp} , the OB2513x will shut down the base output and then latch the power supply off. The controller will remains latched until the die temperature drops below the recovery threshold T_{otp_rec} and the OB2513x will reset at the same

time.

PCB Layout Consideration

The following rules should be followed in OB2513x PCB Layout:

- **The Area of Power Loop:** The area of the main current loop should be as small as possible to reduce EMI radiation, such as the primary current loop, the snubber circuit and the secondary rectifying loop (Red wire as shows in Fig.5). Drain pin increases the copper area of the drain terminal for heat dissipation (Green region as shows in Fig.6). And the PCB trace must be wide and short for thermal consideration.
- **Bypass Capacitor and FB divider resistor:** The bypass capacitor on VDD and the FB divider resistor should be placed as close as

possible to pin out. And the negative node of VDD capacitor and the FB down resistor should be connected directly to the IC GND pin before single point connected to the negative node of the output capacitor. (White region as shows in Fig.6)

- **Ground Path:** The GND path of the input power loop and IC controller path should be separated and connected at the negative terminal of input capacitor by single point, such as power sense resistor, the negative of the auxiliary winding and the IC GND. (White region as shows in Fig.6)

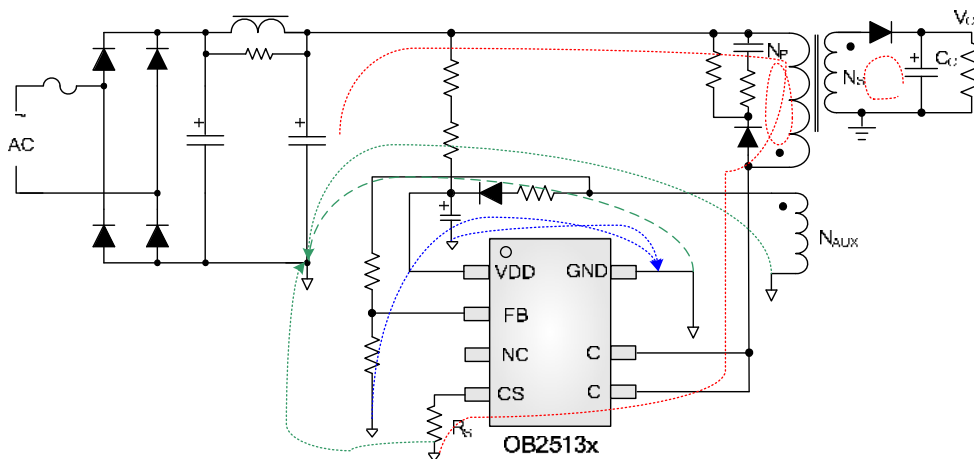

Fig.5 Flyback Schematic with OB2513x

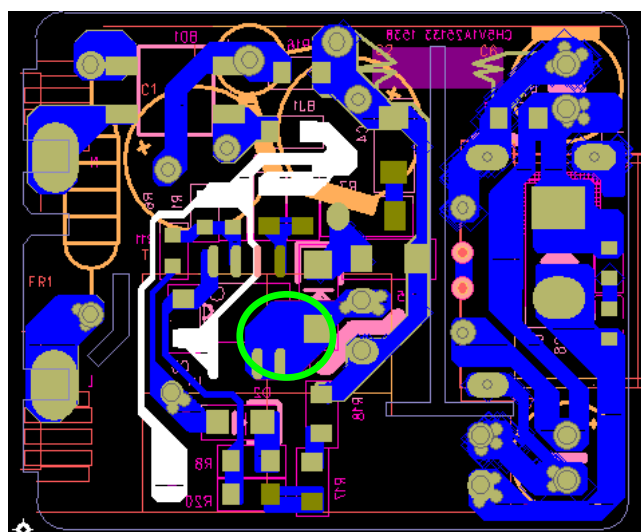
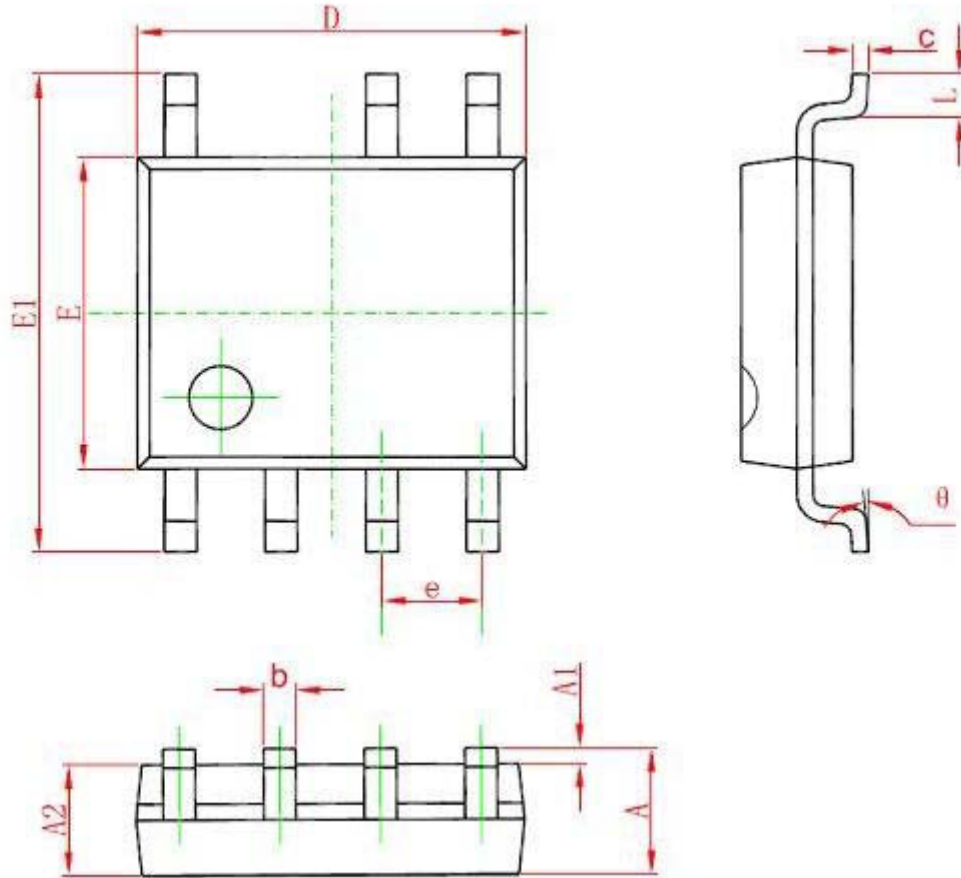

Fig.6 Recommend PCB Layout of OB2513x

PACKAGE MECHANICAL DATA
SOP7 PACKAGE OUTLINE DIMENSIONS



Symbol	Dimensions In Millimeters		Dimensions In Inches	
	Min	Max	Min	Max
A	1.350	1.750	0.053	0.069
A1	0.050	0.250	0.002	0.010
A2	1.250	1.650	0.049	0.065
b	0.310	0.510	0.012	0.020
c	0.100	0.250	0.004	0.010
D	4.700	5.150	0.185	0.203
E	3.800	4.000	0.150	0.157
E1	5.800	6.200	0.228	0.244
e	1.270 (BSC)		0.050 (BSC)	
L	0.400	1.270	0.016	0.050
θ	0°	8°	0°	8°

IMPORTANT NOTICE

RIGHT TO MAKE CHANGES

On-Bright Electronics Corp. reserves the right to make corrections, modifications, enhancements, improvements and other changes to its products and services at any time and to discontinue any product or service without notice. Customers should obtain the latest relevant information before placing orders and should verify that such information is current and complete.

WARRANTY INFORMATION

On-Bright Electronics Corp. warrants performance of its hardware products to the specifications applicable at the time of sale in accordance with its standard warranty. Testing and other quality control techniques are used to the extent it deems necessary to support this warranty. Except where mandated by government requirements, testing of all parameters of each product is not necessarily performed.

On-Bright Electronics Corp. assumes no liability for application assistance or customer product design. Customers are responsible for their products and applications using On-Bright's components, data sheet and application notes. To minimize the risks associated with customer products and applications, customers should provide adequate design and operating safeguards.

LIFE SUPPORT

On-Bright Electronics Corp.'s products are not designed to be used as components in devices intended to support or sustain human life. On-bright Electronics Corp. will not be held liable for any damages or claims resulting from the use of its products in medical applications.

MILITARY

On-Bright Electronics Corp.'s products are not designed for use in military applications. On-Bright Electronics Corp. will not be held liable for any damages or claims resulting from the use of its products in military applications.